

Teori arsitektur – Lecture week 10: Transparency

Eka Permanasari

Rahma Purisari

PRECEDENTS

- Transparency may be an inherent quality of substance → in a glass curtain wall or it may be an inherent quality of organization.
- This is what we call as literal transparency and phenomenal transparency
- Using cubist painting as precedents, Rowe and slutzky gives explanation on the differences between the two.

- Moholy-Nagy: La Sarraz



Single reading: fore ground, middle ground, and background

- Fernand Legger: Three faces

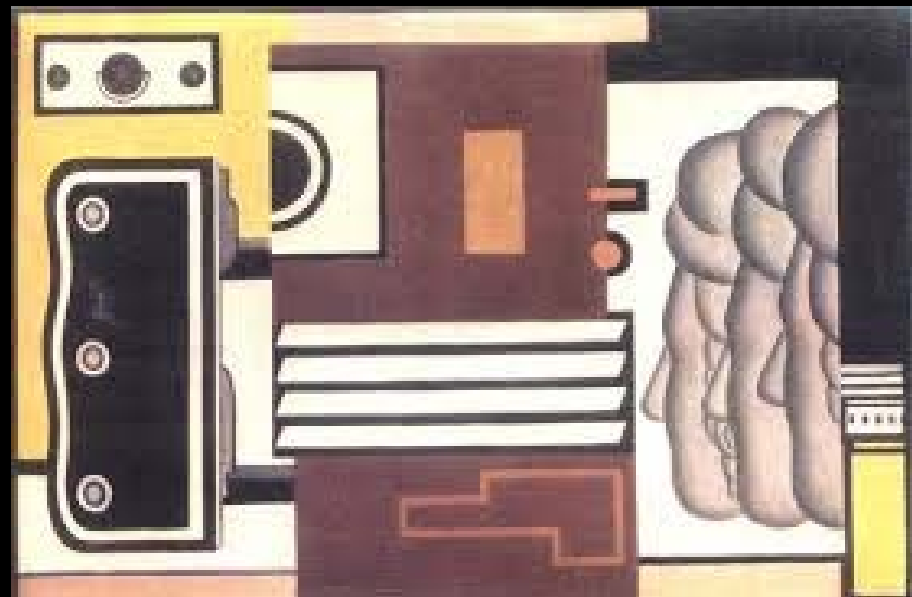

Leger makes completely plain the multifunctional behavior of clearly defined form.

WHY IT IS CALLED AS PHENOMENAL TRANSPARENCY?

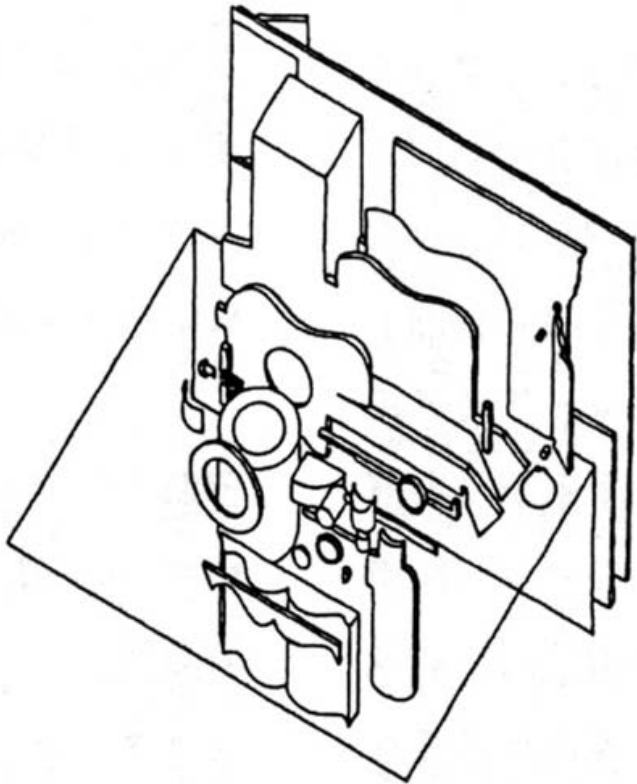

WHY THIS IS CALLED AS LITERAL?

